

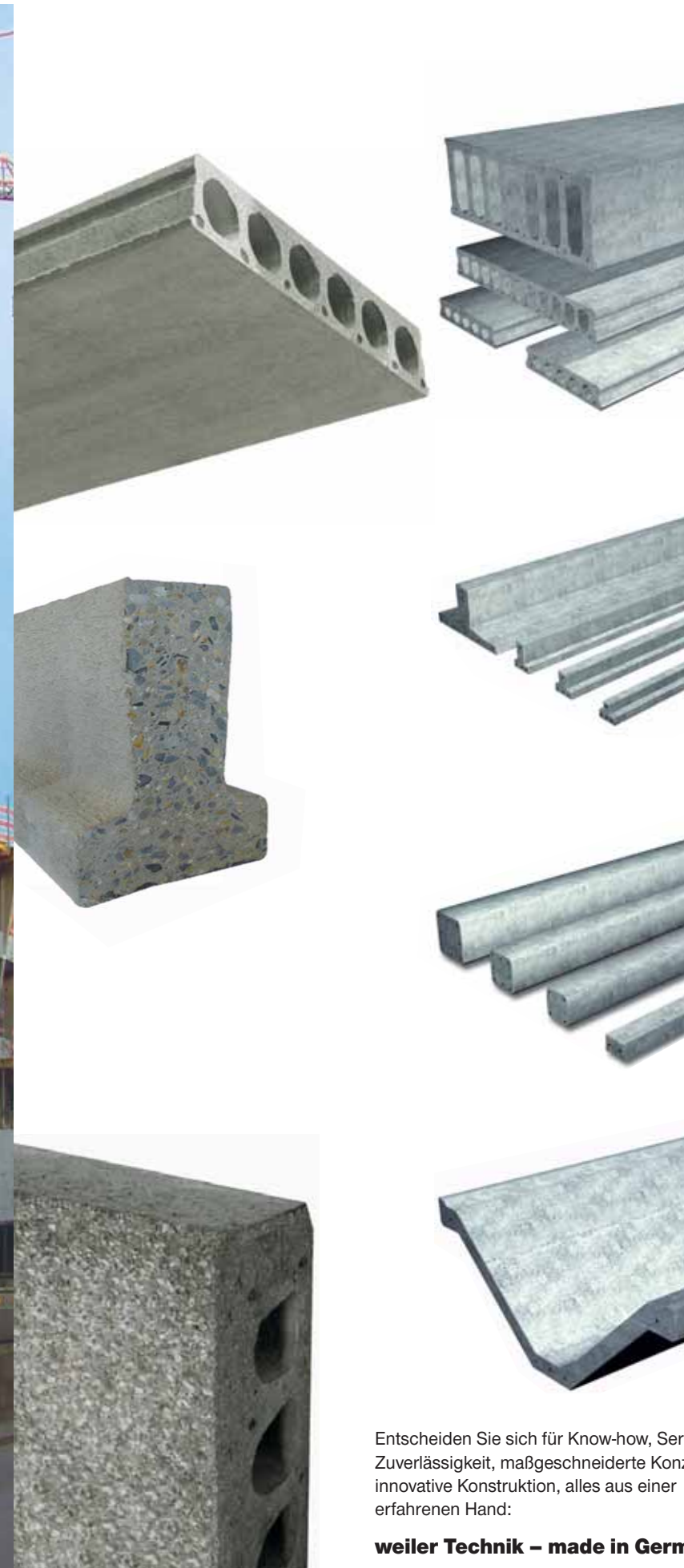

Schlüsselfertige Gleitfertigeranlagen Turn-key Slip Former Plants

Hochwertige maßgeschneiderte Qualität
– flexibel und innovativ
weiler Produkte werden von der internationalen
Betonfertigteilindustrie weltweit im Gewerbe-,
Tief- und privaten Wohnungsbau verwendet.

Tailor-made Quality
– Flexible and Innovative
weiler products are used world-wide by the
international pre-cast concrete industry for civil
engineering, as well as for commercial,
housing, and private construction work.



weiler

Produkte sind ...

products are ...



... glatt & präzise

... smooth & exact



... kostenbewußt & flexibel

... cost-conscious & variable



... preiswert & stabil

... price-worthy & rigid



... lang & Leicht

... long & light

Entscheiden Sie sich für Know-how, Service und Zuverlässigkeit, maßgeschneiderte Konzepte, innovative Konstruktion, alles aus einer erfahrenen Hand:

weiler Technik – made in Germany

Single-source responsibility: decide for your own benefit to get know-how, tailor-made concepts, innovative design, reliability, and service: all from one experienced hand:

weiler Technology – made in Germany

Deckenhohlplatten – Wandplatten
hollow core slabs – wall panels

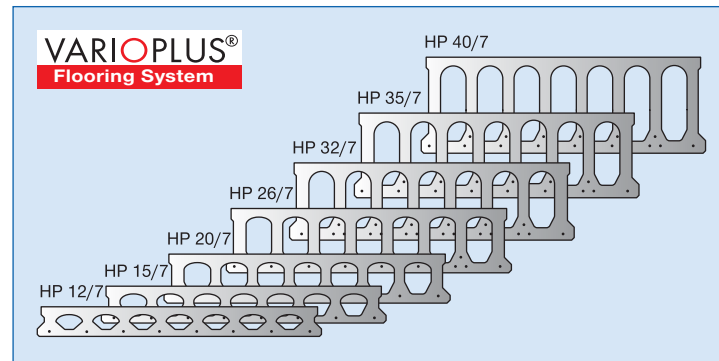

- massive Decken- und Wandplatten von 7 bis 50 cm hoch, von 30 – 240 cm breit Hohlraumanteil bis 50 %.
- *Solid and hollow core slabs and wall panels, 7 to 50 cm high, from 30 to 240 cm wide void percentage up to 50 %*

Deckenträger
floor beams

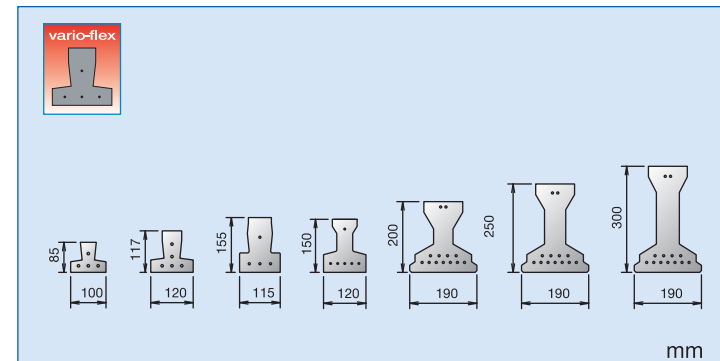

- T- oder I- Deckenträger bis 32 cm hoch Produktion mehrerer Träger gleichzeitig Produktionsgeschwindigkeit bis 3,0 m/min
- *T- or I- beams up to 32 cm high simultaneous production of several beams production speed up to 3,0 m/min*

Fensterstürze, Zaun- und Rammpfähle
lintels, fence posts and foundation piles

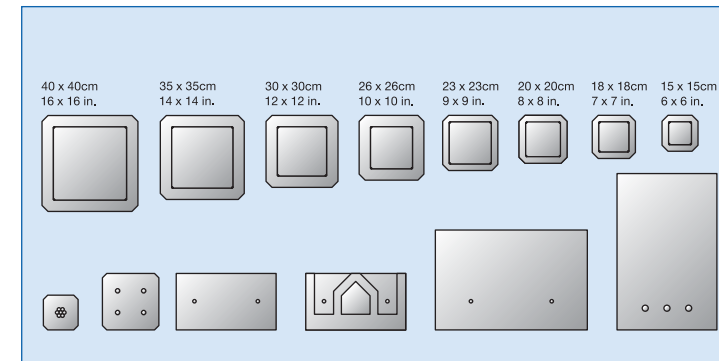

- Zaunpfähle von 4,5x4,5 cm sowie Rammpfähle von 45x45 cm Fensterstürze massive oder ummantelte
- *Fence posts 4,5 x 4,5 cm foundation piles, up to 45 x 45 cm cross section solid or coated lintels*

Dach- und Wandelemente
roof and wall units

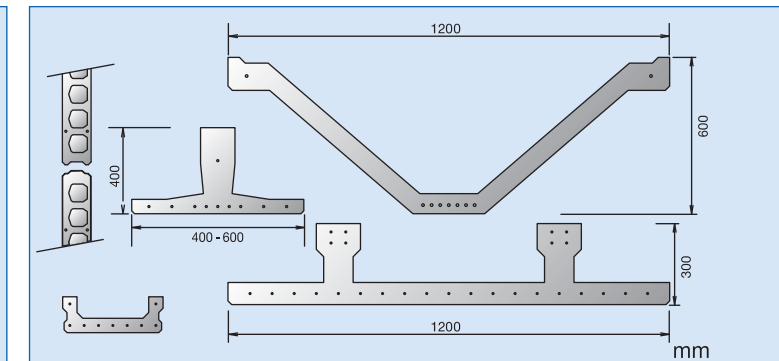

- TT-Platten – massiv oder mit Isolierung Trogplatten, Rippenplatten und V-Elemente – freie Spannweite bis 30 m
- *TT-slabs – for solid or insulated flooring U-channels, ribbed slabs and V-elements – clear span up to 30 m*

Mit dem **weiler** Gleitfertiger werden die verschiedenen Betonfertigteile in mehreren Lagen auf bis zu 200 m langen Spannbetten endlos hergestellt. Nach dem Aushärten werden die Elemente mit einer Betonsäge auf die spezifischen Längen geschnitten.

Different kinds of pre-cast pre-stressed concrete products are continuously cast in multiple stage (one pass-operation) on pre-stressing flat form beds of up to 200 meter length. After sufficient curing, the products are cut to specified lengths with a concrete saw.

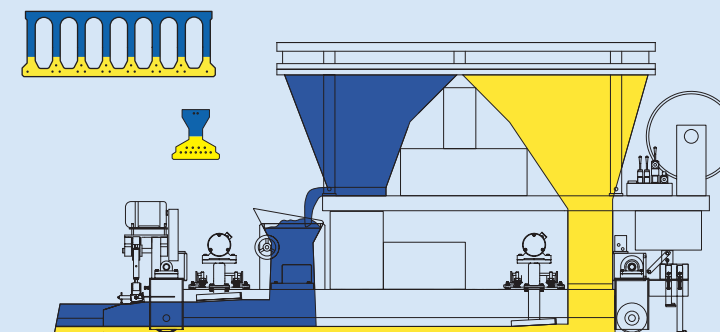

Das **weiler** Universalprinzip:

- Universalbeschickereinheit mit Betonsilo, Elektrik und Hydraulik in Kombination mit dem Maschinensatz.
- Austausch der Schalung für verschieden hohe Hohlplatten mit dem gleichen Maschineneinsatz.
- Verschiedene Produkte mit einem zweiten Maschineneinsatz – Wechsel in nur 5 Minuten.
- Modulprinzip: Einzelne Baugruppen untereinander austauschbar – Umbau ca. 90 Minuten.

The **weiler** Universal Concept:

- *Universal feed unit with concrete hopper, electrical controls and hydraulics, in combination with an additional machinery insert.*
- *By exchanging the mould assembly, different sizes of hollow core slabs can be produced with the same machinery insert.*
- *Other products are possible by using a second machinery insert – change within only 5 minutes.*
- *Modular design: Single groups are interchangeable – conversion with 90 minutes.*



leistungsstarke Hochfrequenzvibratoren, präzise robuste Antriebe
powerful high-frequency vibrators, precision design for high reliability

hydraulische kraftvolle Antriebe – CETOP Norm, schneller Rückwärtsgang
heavy duty hydraulic drives – CETOP standard, fast reversing gear

solide Detailmechanik, hochwertige Maschinenelemente
sound mechanical design details, first-rate quality machinery components

Deutsche Qualitätselektrik, Steuerungen auf höchstem Niveau
German quality electrics, control units on highest level